

<b>DTC</b>	<b>B1647/82</b>	<b>Lost Communication with Front Passenger Side Satellite Sensor Bus</b>
------------	-----------------	--

## DESCRIPTION

The side airbag sensor RH and the rear airbag sensor RH consist of parts including the diagnostic circuit and the lateral deceleration sensor.

When the center airbag sensor assembly receives signals from the lateral deceleration sensor, it determines whether or not the SRS should be activated.

DTC B1647/82 is set when a malfunction is detected in the side airbag sensor RH or rear airbag sensor RH circuit.

DTC No.	DTC Detection Condition	Trouble Area
B1647/82	<ul style="list-style-type: none"> <li>• Center airbag sensor assembly detects open circuit signal in side airbag sensor RH circuit or rear airbag sensor RH circuit for 2 seconds.</li> <li>• Side airbag sensor RH malfunction</li> <li>• Rear airbag sensor RH malfunction</li> <li>• Center airbag sensor assembly malfunction</li> </ul>	<ul style="list-style-type: none"> <li>• Floor wire</li> <li>• Side airbag sensor RH</li> <li>• Rear airbag sensor RH</li> <li>• Center airbag sensor assembly</li> </ul>

## WIRING DIAGRAM

[RS-82](#)

## INSPECTION PROCEDURE

### NOTICE:

**In order to prevent unexpected airbag deployment, disconnect the following connectors before inspecting parts such as wire harnesses, if the application of tester probes to the center airbag sensor assembly connector is necessary.**

1. Turn the ignition switch off.
2. Disconnect the negative (-) terminal cable from the battery, and wait for at least 90 seconds.
3. Disconnect the connector from the center airbag sensor assembly.
4. Disconnect the connectors from the steering pad.
5. Disconnect the connectors from the front passenger airbag assembly.
6. Disconnect the connector from the front seat outer belt assembly LH.
7. Disconnect the connector from the front seat outer belt assembly RH.

### HINT:

Skip the following steps if side airbags and curtain shield airbags are not fitted.

8. Disconnect the connector from the front seat side airbag assembly LH.
9. Disconnect the connector from the front seat side airbag assembly RH.
10. Disconnect the connector from the curtain shield airbag assembly LH.
11. Disconnect the connector from the curtain shield airbag assembly RH.

<b>1</b>	<b>CHECK CONNECTORS (CENTER AIRBAG SENSOR ASSEMBLY - SIDE AIRBAG SENSOR RH)</b>
----------	---

- (a) Turn the ignition switch off.
- (b) Disconnect the negative (-) terminal cable from the battery, and wait for at least 90 seconds.
- (c) Disconnect the floor wire connectors from the center airbag sensor assembly and the side airbag sensor RH.

- (d) Check the floor wire connectors and terminals (on the center airbag sensor assembly and the side airbag sensor RH sides) and check that the connectors are properly connected.

**Result**

Result	Proceed to
No problem.	A
Connectors or terminals incorrect.	B
Connectors connected improperly.	C

**B** REPAIR OR REPLACE FLOOR WIRE

**C** CONNECT CONNECTORS PROPERLY

**A**

**RS**

**2 CHECK FLOOR WIRE (CENTER AIRBAG SENSOR ASSEMBLY - SIDE AIRBAG SENSOR RH)**

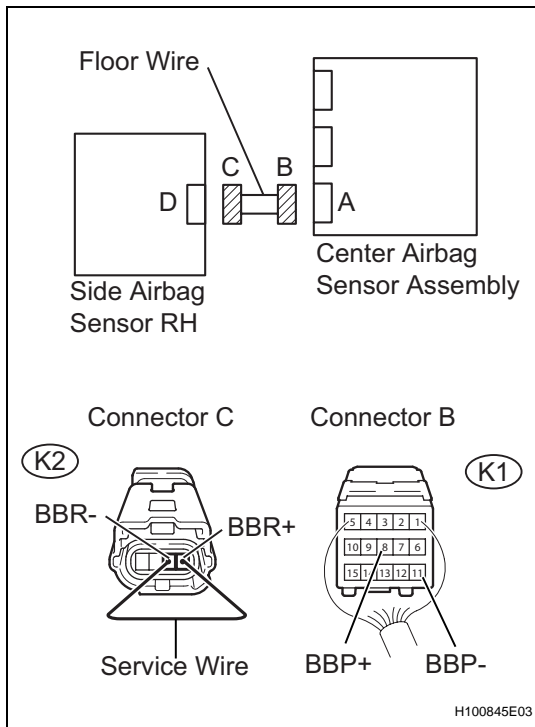

- (a) Check for open in the circuit.
  - (1) Using a service wire, connect K2-4 (BBR+) and K2-3 (BBR-) of connector C.
  - NOTICE:**  
Do not forcibly insert the service wire into the terminals of the connector when connecting.
  - (2) Measure the resistance.

**Standard resistance**

Tester Connection	Condition	Specified Condition
K1-8 (BBP+) - K1-11 (BBP-)	Always	Below 1Ω

- (b) Check for short in the circuit.
  - (1) Disconnect the service wire from connector C.
  - (2) Measure the resistance.

**Standard resistance**

Tester Connection	Condition	Specified Condition
K1-8 (BBP+) - K1-11 (BBP-)	Always	1 MΩ or higher

- (c) Check for short to ground in the circuit.
  - (1) Measure the resistance.

**Standard resistance**

Tester Connection	Condition	Specified Condition
K1-8 (BBP+) - Body ground	Always	1 MΩ or higher
K1-11 (BBP-) - Body ground	Always	1 MΩ or higher

- (d) Check for short to B+ in the circuit.
  - (1) Connect the negative (-) terminal cable to the battery, and wait for at least 2 seconds.
  - (2) Turn the ignition switch to the on position.
  - (3) Measure the voltage.

## Standard voltage

Tester Connection	Condition	Specified Condition
K1-8 (BBP+) - Body ground	Ignition switch on	Below 1 V
K1-11 (BBP-) - Body ground	Ignition switch on	Below 1 V

- (4) Turn the ignition switch off.
- (5) Disconnect the negative (-) terminal cable from the battery, and wait for at least 90 seconds.

NG

REPAIR OR REPLACE FLOOR WIRE

OK

## 3 CHECK SIDE AIRBAG SENSOR RH

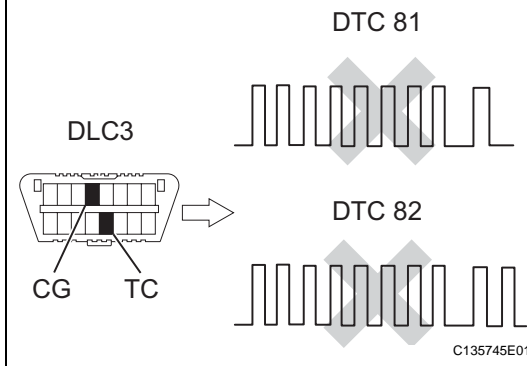
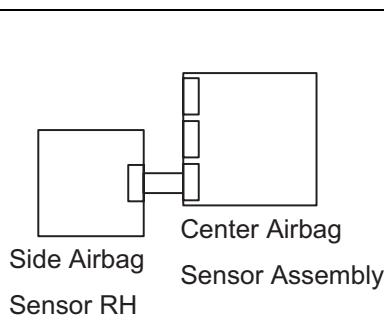

- (a) Connect the connector to the center airbag sensor assembly.
- (b) Interchange the side airbag sensor RH with the side airbag sensor LH and connect the connectors to them.
- (c) Connect the negative (-) terminal cable to the battery, and wait for at least 2 seconds.
- (d) Turn the ignition switch to the on position, and wait for at least 60 seconds.
- (e) Clear the DTCs stored in the memory (See page [RS-36](#)).
- (f) Turn the ignition switch to the lock position.
- (g) Turn the ignition switch to the on position, and wait for at least 60 seconds.
- (h) Check for DTCs (See page [RS-36](#)).

## Result

Result	Proceed to
DTC B1647/82 is output.	A
DTC B1642/81 is output.	B
DTC B1642/81 or B1647/82 is not output.	C

## HINT:

DTCs other than DTC B1642/81 and B1647/82 may be output at this time, but they are not related to this check.

B

REPLACE SIDE AIRBAG SENSOR RH

C

USE SIMULATION METHOD TO CHECK

A

**4 CHECK CONNECTORS (SIDE AIRBAG SENSOR RH - REAR AIRBAG SENSOR RH)**

- (a) Turn the ignition switch off.
- (b) Disconnect the negative (-) terminal cable from the battery, and wait for at least 90 seconds.
- (c) Disconnect the floor wire connectors from the side airbag sensor RH and the rear airbag sensor RH.
- (d) Check the floor wire connectors and terminals (on the side airbag sensor RH and the rear airbag sensor RH sides) and check that the connectors are properly connected.

**Result**

Result	Proceed to
No problem.	A
Connectors or terminals incorrect.	B
Connectors connected improperly.	C

RS

**B** REPAIR OR REPLACE FLOOR WIRE

**C** CONNECT CONNECTORS PROPERLY

A

**5 CHECK FLOOR WIRE (SIDE AIRBAG SENSOR RH - REAR AIRBAG SENSOR RH)**

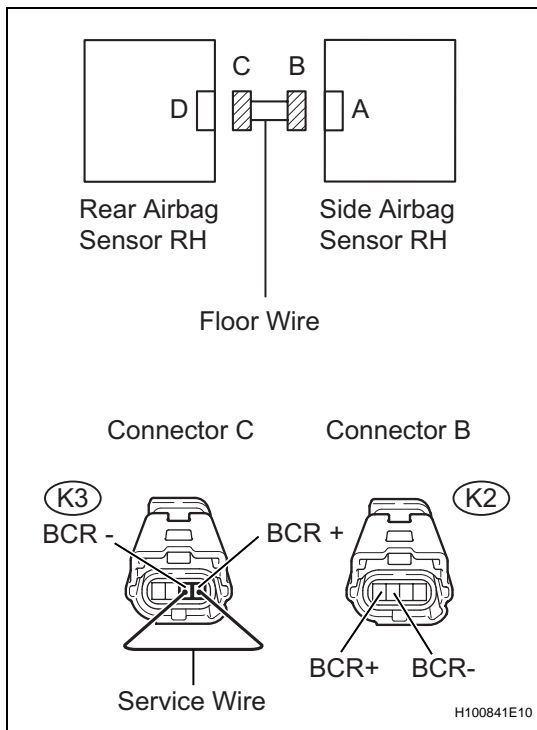

- (a) Check for open in the circuit.
    - (1) Using a service wire, connect K3-1 (BCR-) and K3-2 (BCR+) of connector C.

**NOTICE:**  
Do not forcibly insert the service wire into the terminals of the connector when connecting.

  - (2) Measure the resistance.
- Standard resistance**

Tester Connection	Condition	Specified Condition
K2-1 (BCR+) - K2-2 (BCR-)	Always	Below 1Ω

H100841E10

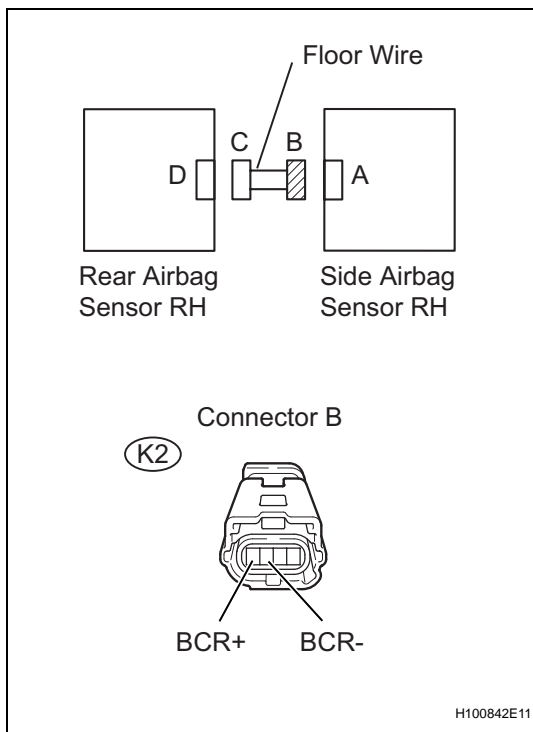

- (b) Check for short in the circuit.
- (1) Disconnect the service wire from connector C.
  - (2) Measure the resistance.

**Standard resistance**

Tester Connection	Condition	Specified Condition
K2-1 (BCR+) - K2-2 (BCR-)	Always	1 MΩ or higher

- (c) Check for short to ground in the circuit.

- (1) Measure the resistance.

**Standard resistance**

Tester Connection	Condition	Specified Condition
K2-1 (BCR+) - Body ground	Always	1 MΩ or higher
K2-2 (BCR-) - Body ground	Always	1 MΩ or higher

- (d) Check for short to B+ in the circuit.

- (1) Connect the negative (-) terminal cable to the battery, and wait for at least 2 seconds.
- (2) Turn the ignition switch to the on position.
- (3) Measure the voltage.

**Standard voltage**

Tester Connection	Condition	Specified Condition
K2-1 (BCR+) - Body ground	Ignition switch on	Below 1 V
K2-2 (BCR-) - Body ground	Ignition switch on	Below 1 V

- (4) Turn the ignition switch off.
- (5) Disconnect the negative (-) terminal cable from the battery, and wait for at least 90 seconds.

NG

**REPAIR OR REPLACE FLOOR WIRE**

OK

**6 CHECK REAR AIRBAG SENSOR RH**

- (a) Connect the connector to the side airbag sensor RH.

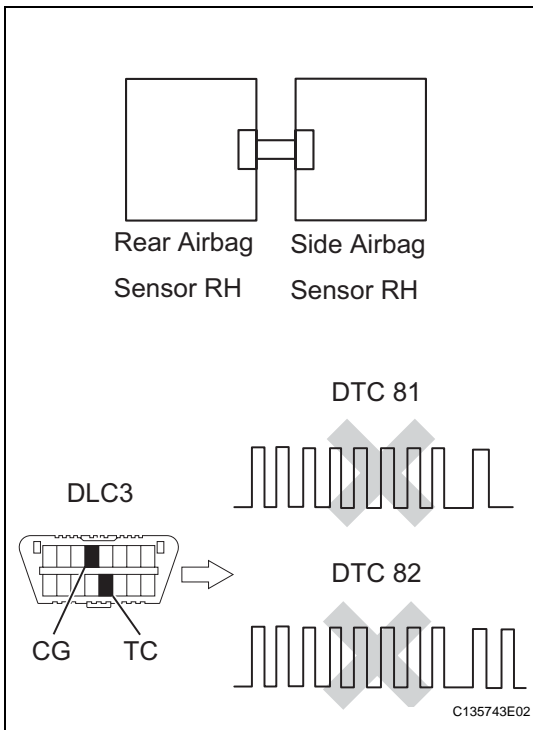

- (b) Interchange the rear airbag sensor RH with the rear airbag sensor LH and connect the connectors to them.
- (c) Connect the negative (-) terminal cable to the battery, and wait for at least 2 seconds.
- (d) Turn the ignition switch to the on position, and wait for at least 60 seconds.
- (e) Clear the DTCs stored in the memory (See page RS-36 ).
- (f) Turn the ignition switch to the lock position.
- (g) Turn the ignition switch to the on position, and wait for at least 60 seconds.
- (h) Check for DTCs (See page RS-36 ).

RS

**Result**

Result	Proceed to
DTC B1642/81 or B1647/82 is not output.	A
DTC B1647/82 is output.	B
DTC B1642/81 is output.	C

**HINT:**

DTCs other than DTC B1642/81 and B1647/82 may be output at this time, but they are not related to this check.

- B** → REPLACE CENTER AIRBAG SENSOR ASSEMBLY
- C** → REPLACE REAR AIRBAG SENSOR RH

**A**

**USE SIMULATION METHOD TO CHECK**